

A

B

C

D

E

F

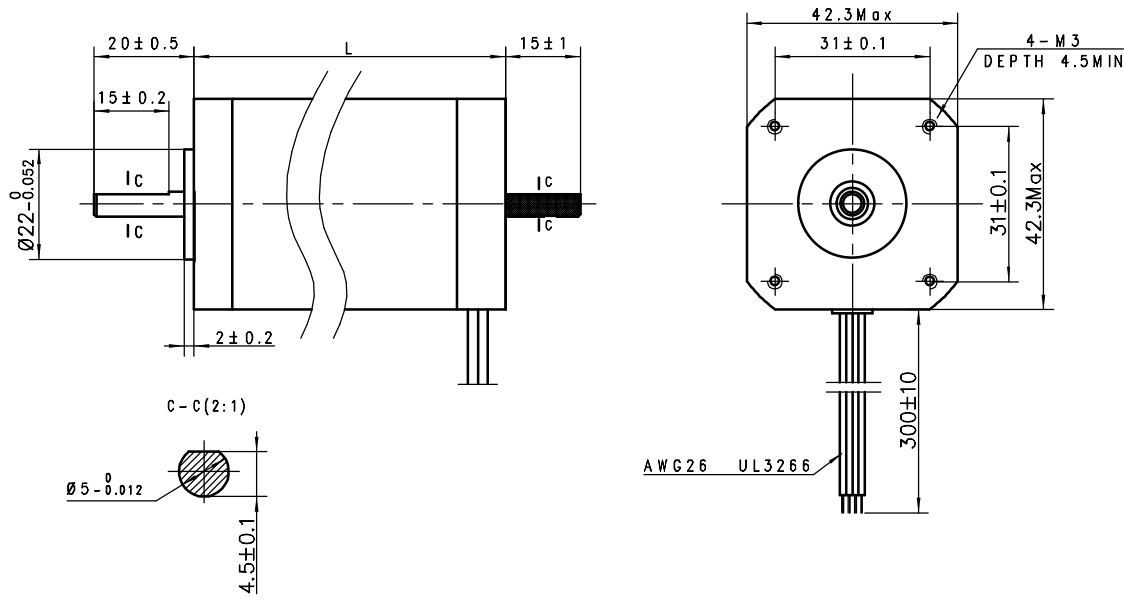

■此外形图为双轴产品。单轴产品无(■)部分的转轴

型号	长度(L)
AM17HD4452-01N	34.3
AM17HD4452-02N	34.3
AM17HD2438-01N	39.8
AM17HD2438-02N	39.8
AM17HD6426-05N	48.3
AM17HD6426-06N	48.3
AM17HDB410-01N	62.8

Unit: mm
 第一角画法
 FIRST ANGLE METHOD
 未注线性与角度尺寸公差
 Tolerances for linear and angular dimensions without individual tolerance indications
 GB/T 1804-m eqv ISO 2768-1:m
 未注形状与位置尺寸公差
 Geometrical tolerances for features without individual tolerance indications
 GB/T 1184-K eqv ISO 2768-2:K

批准 Approve
 标准化 Standard
 工艺 Technology
 审核 Check
 设计 Design

MOONS' Hybrid Stepping Motor
 SHANGHAI AMP & MOONS' AUTOMATION CO.,LTD
 This document is released for information only. Its reproduction in whole or in part or its dissemination to third parties is prohibited. All trademarks and registered trademarks appearing on this document are the property of their respective owners.

REV.	版本记录 REVISION RECORD	DATE	UNLESS OTHERWISE SPECIFIED	NAMES	SIGNATURE	DATE	SCALE 1:1	Sheet 1 of 1
1	原始版本 Original revision							

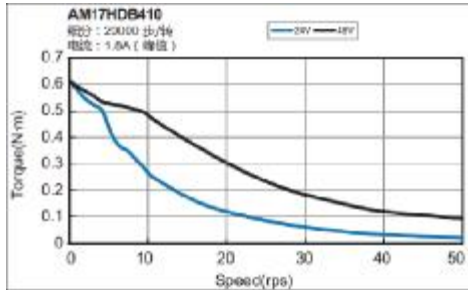
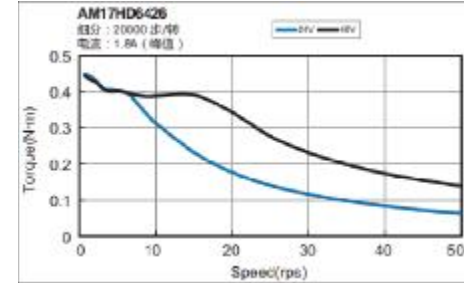
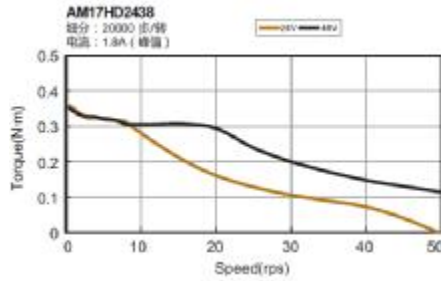
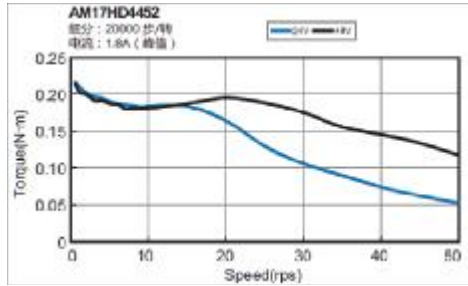

匹配驱动	产品系列	产品名称		步距角 (°)	安装尺寸 (mm)	长度	静力矩 (N.m)	电流 (A)	转子惯量 (g.cm ²)	重量 (Kg)	出线数	出轴形式
		系列代号	产品型号									
SR/ST	NEMA17	AM17HD	AM17HD4452-01N	1.8	42	34.3	0.25	1.8	38	0.23	4	双出轴
			AM17HD4452-02N						38	0.23	4	单出轴
			AM17HD2438-01N			39.8	0.4		57	0.28	4	双出轴
			AM17HD2438-02N						57	0.28	4	单出轴
			AM17HD6426-06N			48.3	0.5		82	0.36	4	单出轴
			AM17HD6426-05N						82	0.36	4	双出轴
			AM17HDB410-01N			62.8	0.85		1.6	123	0.6	4



		Unit: mm		批准 Approve		MOONS'		Hybrid Stepping Motor	
		第一角画法 FIRST ANGLE METHOD		标准化 Standard				SHANGHAI AMP & MOONS' AUTOMATION CO.,LTD	
		未注线性与角度尺寸公差 Tolerances for linear and angular dimensions without individual tolerance indications GB/T 1804-m eqv ISO 2768-1:m		工艺 Technology		This document is released for information only. Its reproduction in whole or in part or its dissemination to third parties is prohibited. All trademarks and registered trademarks appearing on this document are the property of their respective owners.			
		未注形状与位置尺寸公差 Geometrical tolerance for features without individual tolerance indications GB/T 1184-K eqv ISO 2768-2:K		审核 Check					
原始版本 Original revision				设计 Design					
REV.	版本记录 REVISION RECORD	DATE	UNLESS OTHERWISE SPECIFIED	NAMES	SIGNATURE	DATE		SCALE 1:1	Sheet 1 of 1